

# MPF P

Positive feeder: even better



**The many new design features of the MPF P considerably increase the productivity of knitting machines.**

The device is complete with the tried-and-tested, self-cleaning vibration tension, which reliably prevents false stoppages. Our design engineers paid particular attention to making threading easier and faster. The colour-change stop light is an integral part of the feeder body and features the latest LED technology. The light is clearly visible from any operator position.

The enclosed feeder body and the contactless stop motion system ensures immediate, reliable machine stoppage in the event of yarn breakages. The unit can be connected to a 12/24 V AC/DC shutdown current circuit. This makes it suitable for use on a wide variety of knitting machines.

The MPF P guarantees the trouble-free production of faultless fabric on your large diameter circular knitting machines.

## ADVANTAGES

- Self-cleaning vibration tension, prevents false stoppages.
- Rapid threading thanks to open eyelets.
- Interchangeable feed wheel. Fully enclosed feed wheel as standard. Separation and pin feed wheel also available as optionals. We recommend the separation feed wheel for working with single-filament or fine gauge yarn.
- Minimum yarn outfeed tension approx. 1.0 cN
- Support arm as an integrated part of the MPF ensures shorter downtime when the drive belt breaks
- In case of a stoppage, the inlet sensor pivots in the opposite direction to the yarn feed direction, so false stoppages during cleaning are avoided. This makes cleaning times shorten, and productivity is increased
- The colour-change light is an integral part of the feeder body. The light is clearly visible from any position.
- Integrated anti-filamentation unit on the yarn outlet
- Contactless stop motion system.
- Separate sensor catch for the infeed and outfeed stop motion devices.



▶ MPF P

# Components MPF P

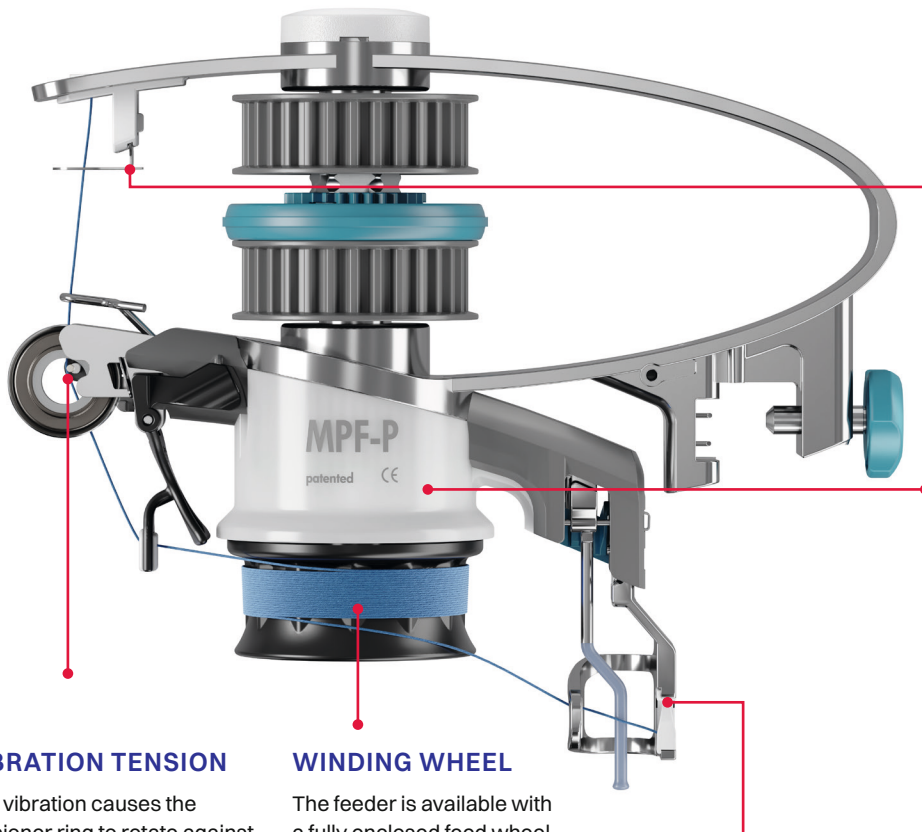

## KNOT CATCHER

This can be changed without tools. Optional - Adjustable knot catcher

## STOP WARNING LIGHT

The large, stop warning light is an integral part of the feeder body and is clearly visible from all operator positions.

## VIBRATION TENSION

The vibration causes the tensioner ring to rotate against the direction of rotation in comparison with other makers. This prevents the build up of dirt between the tension rings which are self-cleaning. No tensioner ring wear. No more fault stoppages means that knitting machine productivity increases.

## WINDING WHEEL

The feeder is available with a fully enclosed feed wheel as standard or with pin type or separation feed wheel as optionals. Rapid changeover.

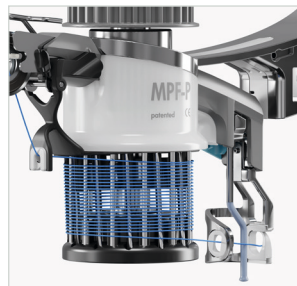

Separation feed wheel

## INTEGRAL ANTI-FILAMENTATION UNIT

When processing filament yarns capillary filaments can collect on the feed wheel and interfere with smooth yarn feed. The user can prevent this by selecting flat pulling for fibre yarns and pulling at a steep angle for filament yarns.

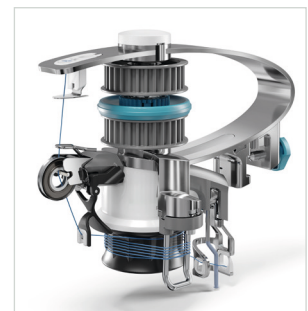

## MPF PF VERSIONS

The MPF PF version from the MPF P series is designed for constant and variable yarn consumption applications. In the friction mode the unit can be used as a feeder on drop stitch and mini Jacquard patterns.

## TECHNICAL DATA

|   |                              |                 |
|---|------------------------------|-----------------|
| Power supply:                               | 12/24 V AC or DC, 50 - 60 Hz |                 |
| Max. current consumption in fault stoppage: | 60 mA                        |                 |
| Number of yarn windings on feed wheel:      | 20                           |                 |
| Yarn tension range:                         | 1 - 20 cN                    |                 |
| Yarn gauge range:                           | Staple yarn:                 | Nm 6 to Nm 200  |
|   | Filament yarn:               | 8 to 2,000 dtex |
|   | Elastomer:                   | spun, wound     |

## ADVANCED KNITTING TECHNOLOGY

MEMMINGER-IRO GMBH  
 Jakob-Mutz-Straße 7 | 72280 Dornstetten-Germany  
 Tel. +49 7443 281-0 | info@memminger-iro.de  
 www.memminger-iro.de

