

MRA 2

Motor drive belt: Improved construction, better fabric quality and higher performance



The MRA 2 motor drive belt completely replaces the quality adjustment pulley assembly.

Servomotors set new standards. Drive belts are now driven separately with each belt having its own servomotor. Motors are set and controlled from a central terminal.

The MRA 2 is designed for use on all circular knitting machines. With MRA 2 setup times are greatly reduced to as little as a tenth of the time needed previously. Fabric quality changes can be made at any time and can be performed by unskilled personnel. Machine downtime is reduced because belts now last longer and require changing less frequently. Fabric quality is improved and article reproducibility is even more accurate.

ADVANTAGES

- Constant, precise stitch length, not otherwise possible with other methods currently in use
- Improved fabric quality due to constant, uniform, programmed yarn infeed rates on all machines
- No mechanical settings and so there is no risk of setting faults. Shorter setup times. These are all factors which add up to high production rates and lower costs
- Big reduction in setup times. The setting of changes and new settings take less than a minute. With the quality adjustment pulley system used previously these operations would take between 10 and 20 minutes
- Rapid fabric press-off rectification thanks to reduction in yarn feed rates
- Greater flexibility. Motor has two-way rotation and can drive left-hand and right-hand feeders on S and Z yarns



▶ MRA 2

Components MRA 2

SERVOMOTORS

These power the drive belts at exactly the speed required for the present yarn feed rate.



CONTROL UNIT

This feeds the power supply to the servomotors and can power up to 6 servomotors. Information from the operator terminal and encoder is stored and forwarded to the servomotors.

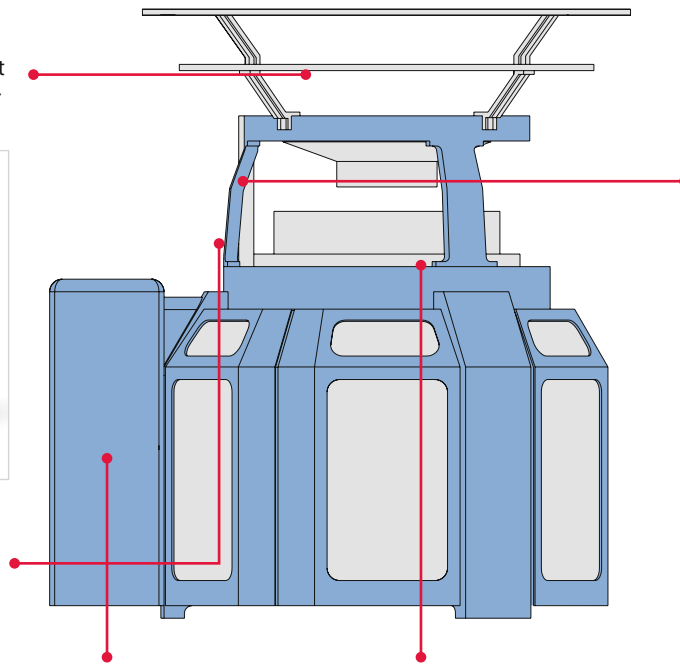

OPERATOR PANEL

Is used to enter all the installation and operating parameters.



CAPACITORS

In the event of a mains power failure, the capacitors ensure that the system continues running until the machine has come to a complete standstill; this prevents yarn breakage.

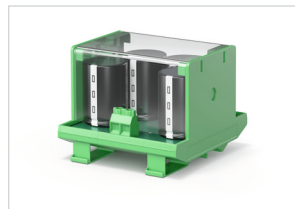

ENCODER

The encoder detects cylinder movements and transmits the corresponding pulses to the control unit.



TECHNICAL DATA

Power supply:	3 x 400 V AC, other voltages possible with upstream transformer
Line frequency:	45 - 66 Hz
Power rating:	250 VA per servomotor
Max. number of feeders driven:	60 MPF per belt per servomotor, 24 MER per belt per servomotor
Max. belt speed:	360 m/min (with 30-tooth drive pulley) 500 m/min (with 40-tooth drive pulley) 576 m/min (with 48-tooth drive pulley)
Length of connecting cable between control unit and servomotor:	1.8 m or 3.0 m

ADVANCED KNITTING TECHNOLOGY

MEMMINGER-IRO GMBH
Jakob-Mutz-Straße 7 | 72280 Dornstetten-Germany
Tel. +49 7443 281-0 | info@memminger-iro.de
www.memminger-iro.de

